



10
YEARS OF
GUARANTEE

OUTSTANDING

- Industrial fence manufactured with highly rigid metal sections
- Robust appearance of the fence
- Very strong circular section posts
- Rapid and simple erection
- Non-removable security screw system
- Unique and versatile post/frame fastening system

Application places



Warehouses & factories Fairs & exhibitions Parks & gardens Residential houses Train stations

Assembly

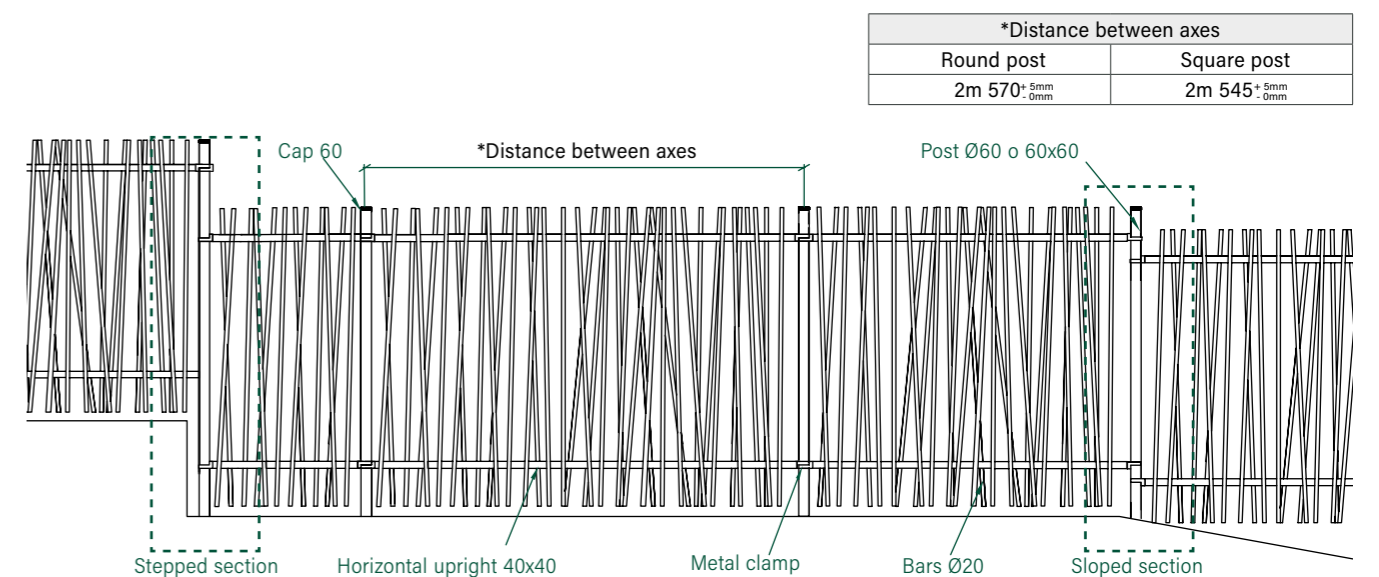

THE STEPPED SECTION AND THE SLOPING SECTION

- The post and frame are fastened together using metal straps manufactured of sheets 1.5 mm thick, that give it a robustness and aesthetic qualities while being discreet.
- Non-removable safety bolt system that offers a perfect

technical solution with a high level of aesthetics.

- The strap model alone can provide changes in direction at different angles, slopes and stepped sections without the need for welds.

Technical features

POST

- Ø60x2mm or Ø60x3mm steel-plated posts, depending on height
- Polypropylene cap which will not degrade in harsh weather Ø60x2mm or Ø60x3mm steel-plated posts, depending on height
- Polypropylene cap will not degrade in harsh weather

Round post detail

Profile Ø60x2mm
Profile weight: 2.86Kg/ml
Galvanised sheet metal Z-275
I/V= 5.11cm³

Profile Ø60x3mm
Profile weight: 4.22Kg/ml
Galvanised sheet metal Z-275
I/V= 7.29cm³

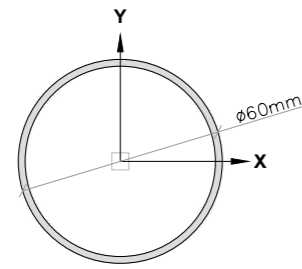

Square post detail

Profile weight 3.56Kg/ml
Galvanised sheet metal Z-275
Thickness: 2mm
I/V= 8.38cm³

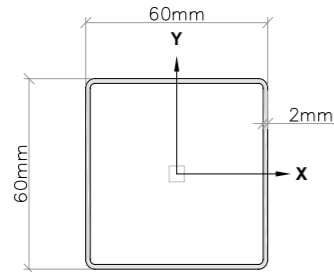

PANEL

- Panel made of 40x40x1.5 horizontal sections and vertical sections diameter 25x1.5 mm ep random implementation
- Rapid assembly without welding

Round post detail

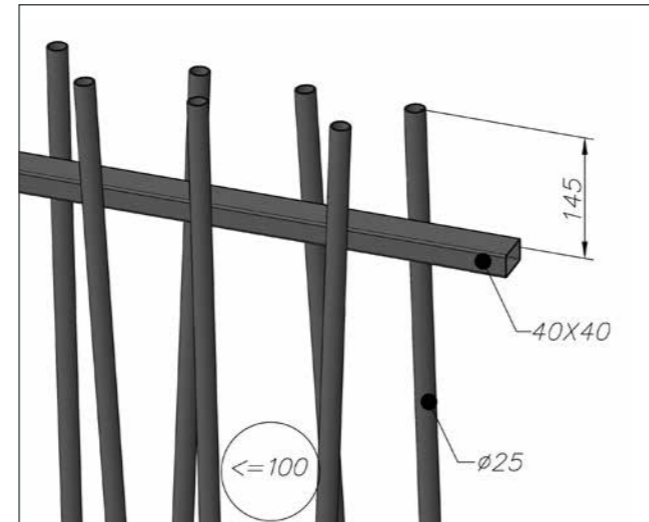

FENCE HEIGHT	PANEL		POST					
			ROUND POST		SQUARE POST		LENGTH	
	LENGTH	TYPE	TYPE (mm)	DISTANCE BETWEEN AXES	TYPE (mm)	DISTANCE BETWEEN AXES	FOUNDATION	PLATE
1m00	2m480	1m00	Ø60x2	2m570 +5mm -0mm	60x60x2	2m545 +5mm -0mm	1m30	1m05
1m20		1m20					1m50	1m25
1m50		1m50					1m90	1m55
1m80		1m80	2m15				1m85	
2m00		2m00	2m35				2m05	
2m40		2m40	2m90				2m45	

NOTE: For sections with more than 10 frames, it is advisable to readjust the interaxes so as not to accumulate errors in the measurement.

Fence height

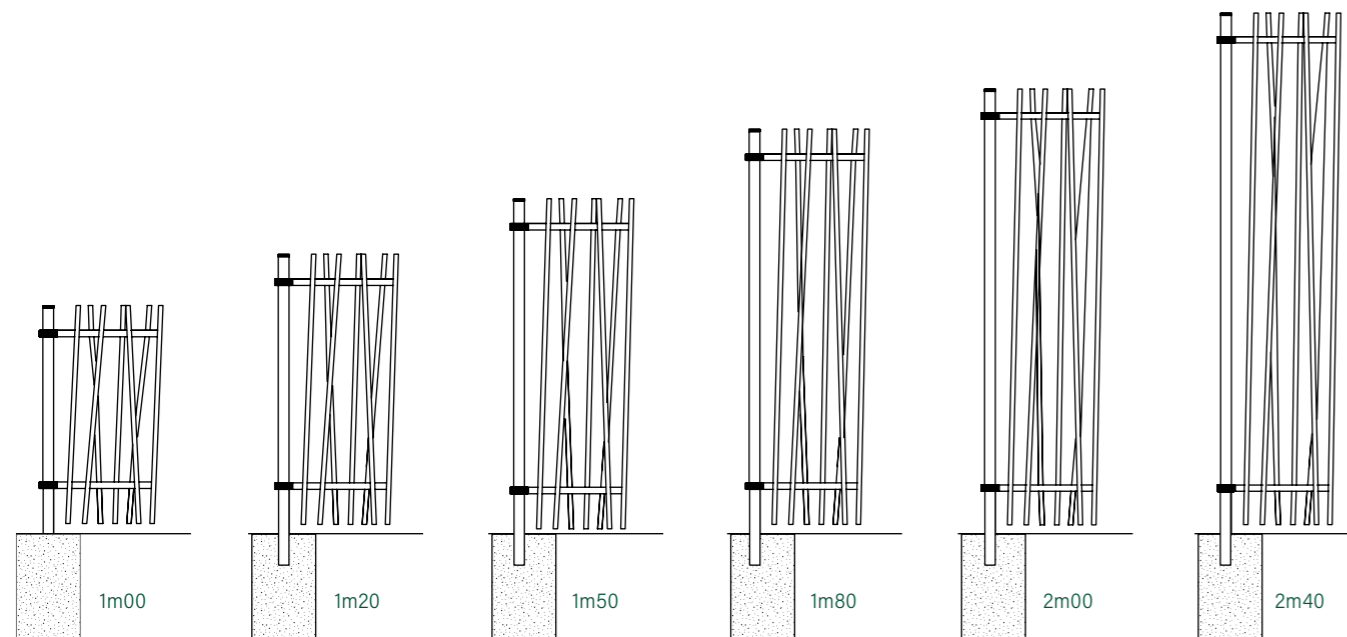

Round post

The connection between the post and the frame is made with 1.5mm thick sheet metal clamps, which offer a robust but discreet appearance.

ROUND POST CONNECTION SYSTEM APPLICATION	
APPLICATION	Ø60mm round posts
MATERIAL	Metal clamps made of 1.5mm thick galvanized sheet metal.
FINISHING	The clamps are plasticized with Rivisa's Protecline coating system and in the same color as the gate.
COMPOSITION	Clamp + Bolts and screws

UNITS PER POST	
INTERMEDIATE POSTS / ANGLE	4 pcs. post
EXTREME POSTS	2 pcs. post

INTERMEDIATE POST

Install the fitting to make a special-width panel and screw the assembly to the post fixing.

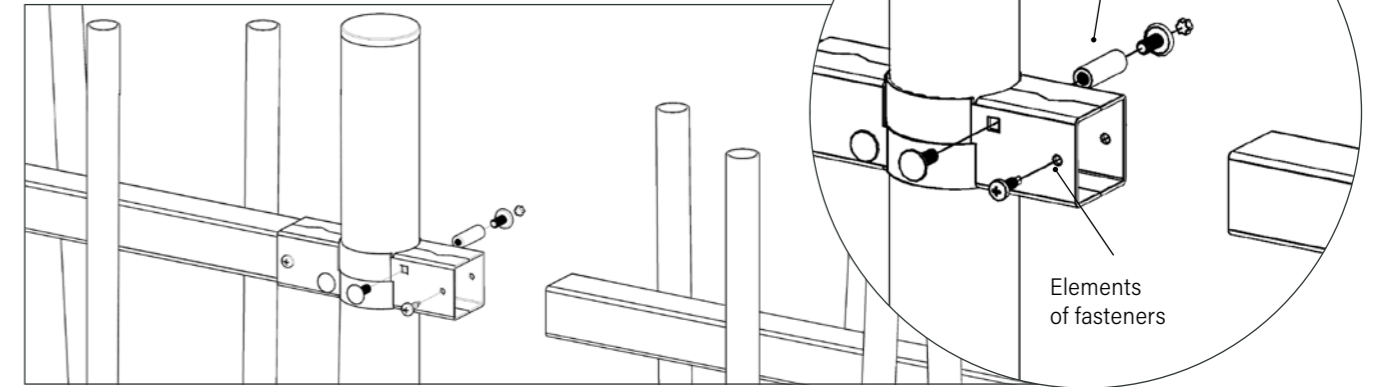

Square post

The connection between post and frame is made with high-strength plastic bushes.

SQUARE POST CONNECTION SYSTEM	
APPLICATION	Square posts 60x60mm
MATERIAL	Bushings made of polypropylene
FINISHING	Black polypropylene
COMPOSITION	Bushing + M8 Screw + M8 Nut

INTERMEDIATE POSTS	
INTERMEDIATE POSTS	4 pcs. Bushing + 2 pcs. screws
ANGLE POSTS	4 pcs. Bushing + 4 pcs. screws
EXTREME POSTS	2 pcs. Bushing + 2 pcs. screws

INTERMEDIATE POST

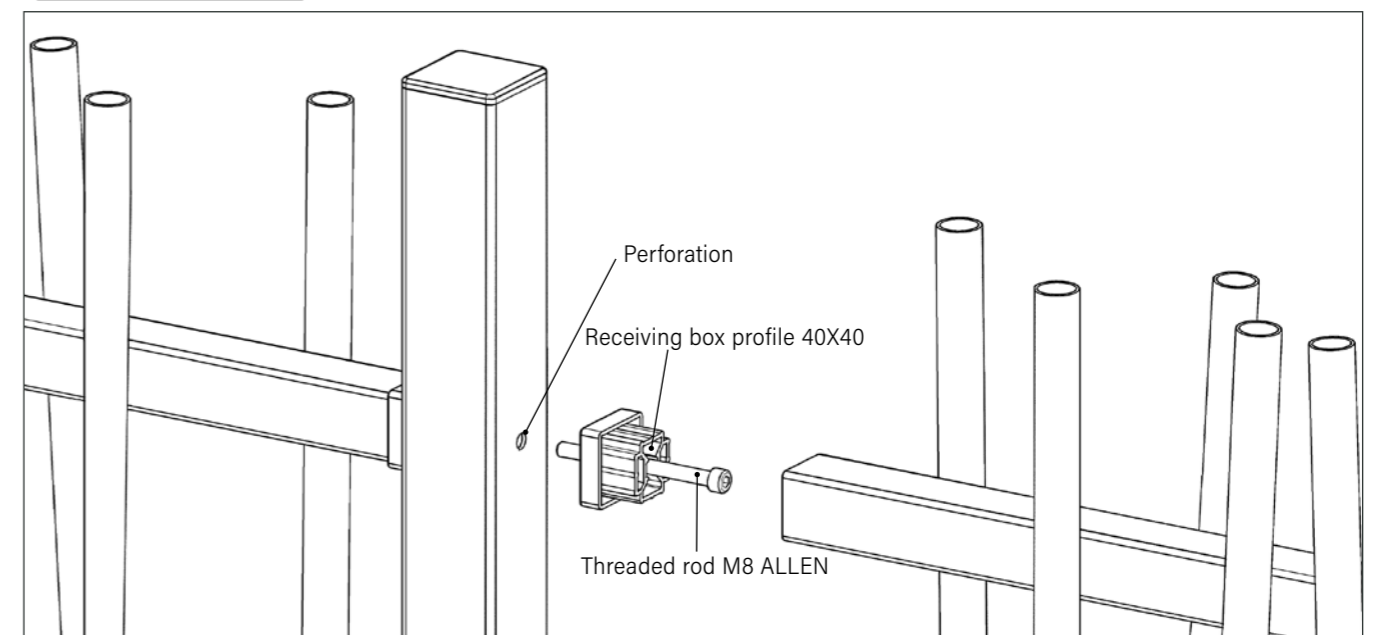

Anchoring systems

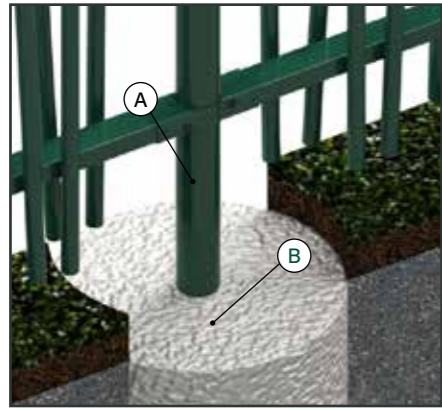

FOUNDATION
Post installation with concrete footings
A. Post Nature
B. Foundation

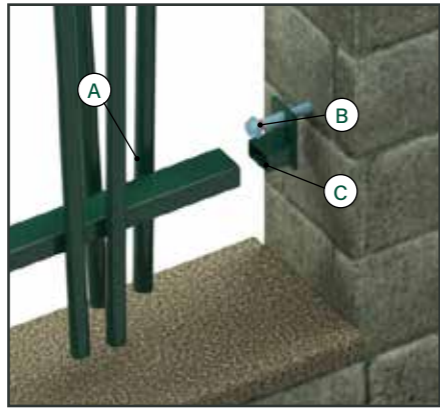

WIDTHR
Option of installing the fence with a side plate.
A. Frame Nature fence
B. Base plate
C. Anchor

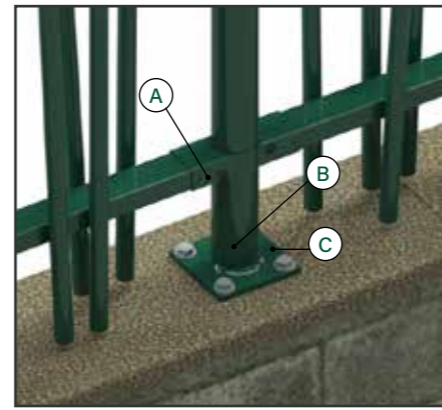

BASE PLATE
A base plate can be used to install the posts on the concrete wall, or for fences less than 2m high.
A. Nature fence post
B. Base plate
C. Anchor

Anticorrosion coating

All the materials of system are hot dip galvanised and plastic coated with **Rivisa® Protecline** anticorrosion coating system.

- Minimum thickness: 100 microns
- Option of applying the **Rivisa® Protecline Plus** plastic coating, which prolongs the useful life of the materials
- Option of applying the **Rivisa® Protecline Plus triple** plastic coating, which prolongs the useful life of the materials
- Available in several colours from the Rivisa RAL chart. Colours:



protecline

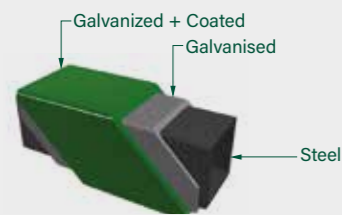

protecline PLUS

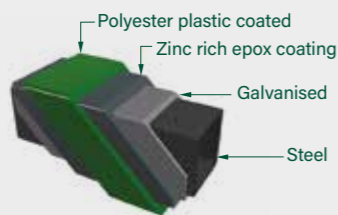

protecline TRIPLE

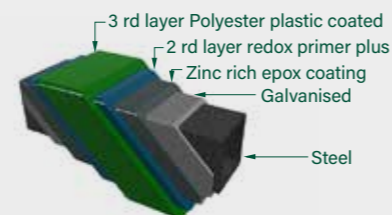

Assembly manual

Preparing the ground

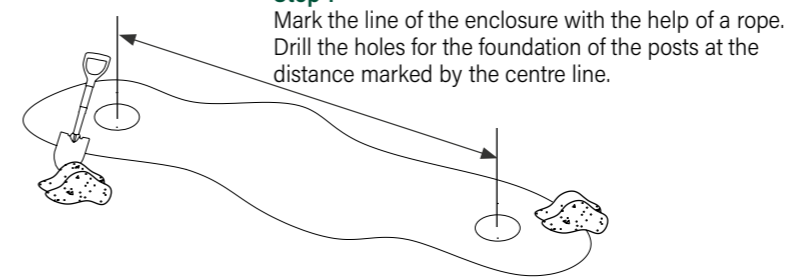

Preparing the ground

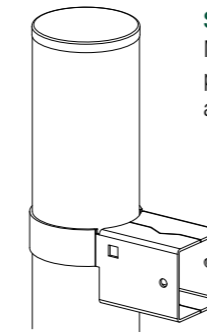

Step 3
Mount the metal clamp on the post (4 pcs. per intermediate post and 2 pcs. per end post).

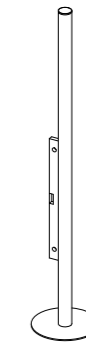

Step 2
Lay the first post on the foundation and plumb it with the help of a level.

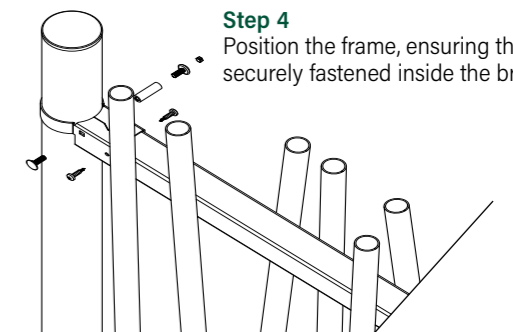

Step 4
Position the frame, ensuring that it is securely fastened inside the brackets.

Frame and end section assembly

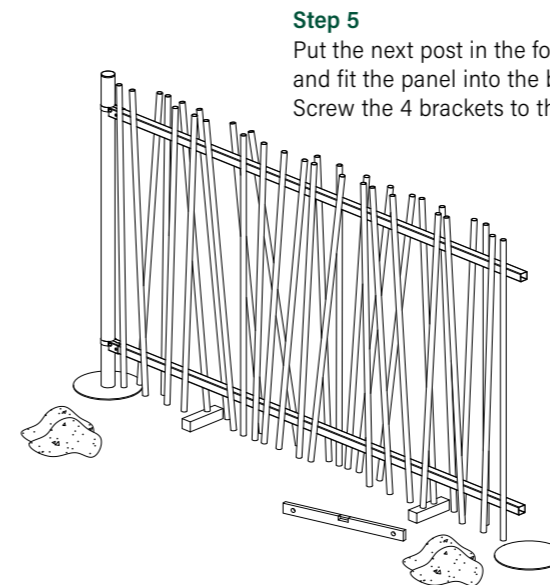

Step 5
Put the next post in the foundation and fit the panel into the brackets. Screw the 4 brackets to the frame.

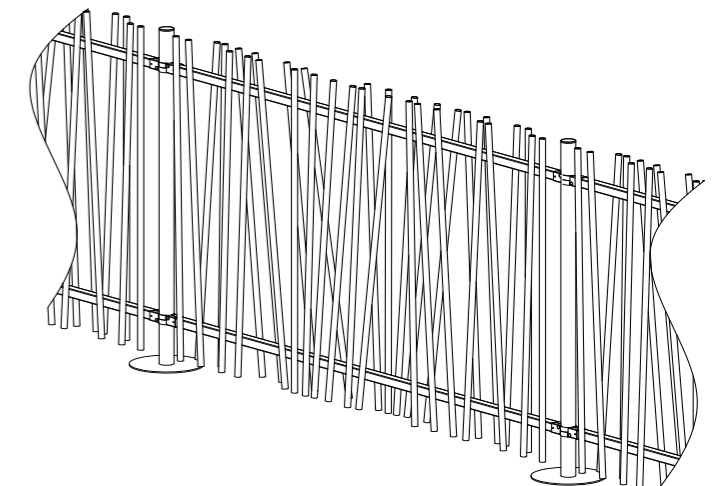

Step 6
Repeat as many times as necessary. If base plate anchoring has been used instead of foundation anchoring, screw on the base and insert the first post. Hook in the panel and insert the next post.

