



10
YEARS OF
GUARANTEE

OUTSTANDING

- Gates manufactured from very rigid metal sections
- Robust gate appearance
- Versatile for openings
- Perfect adjustment of the gate leaves
- High quality materials and accessories
- Locking system with anti-levering feature
- Gates approved to the CE standard

Application places



Warehouses and factories Fairs & exhibitions Residential areas Parks and gardens Train stations

Assembly

ONE-LEAF GATE

Interior right opening (standard)

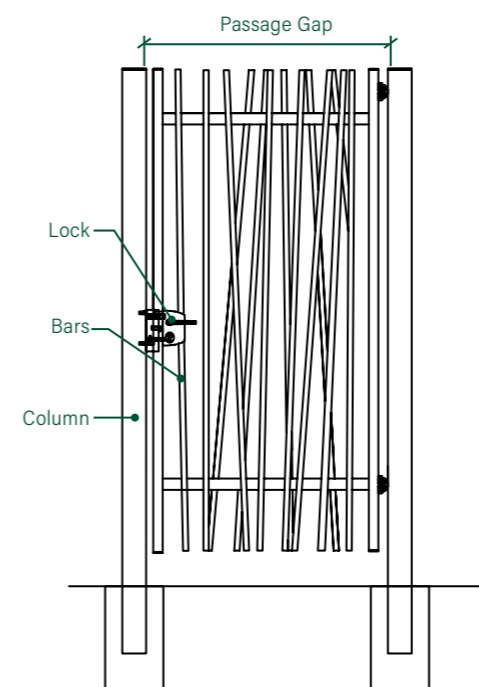

TWO-LEAF GATE

Interior opening (standard)

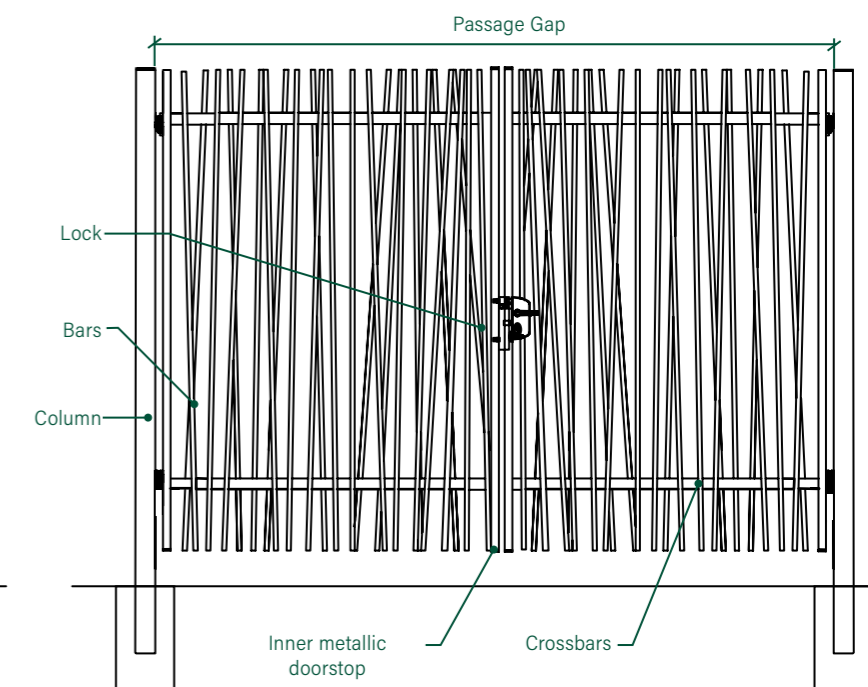

Technical features

- Leaves consisting of rectangular profile frame and bars, Ø25mm.
- Square profile support columns (see table).
- Adjustable hinges that allow enhanced adjustment of the door.
- Lock fitted with stainless steel box and stainless steel mouthpiece (see detail).
- Bayonet for thorns attached to the uprights of the leaf with non-detachable threaded rods.

DESCRIPTION		WEIGHT (Kg)	HEIGHT (mm)	TOTAL WIDTH (mm)	PASSAGE GAP (mm)	COLUMNS (MM)	NO. OF LEAVES	PROFILE BARS (mm)	BARS (mm)	CROSSBARS (mm)
LENGTH	HEIGHT									
1m00	1m50	24	1470	1252	1165	100x100x2	1	Ø25x1.5	60x40x1.5	60x40x1.5
	2m00	32								
3m00	2m00	108	2000	3310	3110	100x100x2	2	Ø25x1.5	60x40x1.5	60x40x1.5
4m00	2m00	131	4151	3951						

Accessories standard swing gate



180° HINGE WITH 4-DIMENSIONAL ADJUSTMENT

Hot-dip galvanised 180° hinge with 4-dimensional adjustment. Depth, height and distance between post and gate are adjustable after installation.



METAL BOLT

Assembly consisting of a metal stop anchored to the floor and a latch mounted in the centre of the two leaves to prevent the door from being opened from the outside.



SECURITY LOCK

Stainless steel security lock for metal doors. The patented stainless steel anchoring system prevents the leaves from separating.



METAL STOP

Metal stop for swing gates with internal opening.



INDUSTRIAL LOCK

Industrial lock with aluminium housing and stainless steel mechanism.



Marking of swing doors

Rivisa® complies with the standard: **EN-13241-1:2003** which defines the safety and performance requirements for swing doors when installed in areas accessible to people. Rivisa® standard doors successfully passed the "TEST OF DECLARATION OF CONFORMITY" to obtain the certificate.

Accessory pillar for residential complex

RESIDENTIAL SET

Complete installation kit for residential gates, with different combinations that allow aesthetic and functional needs to be met in residential areas. There are several combinations for the residential kit:

- Sliding gate + pedestrian access gate with magnetic lock
- Double leaf mechanised gate + pedestrian access gate with magnetic lock

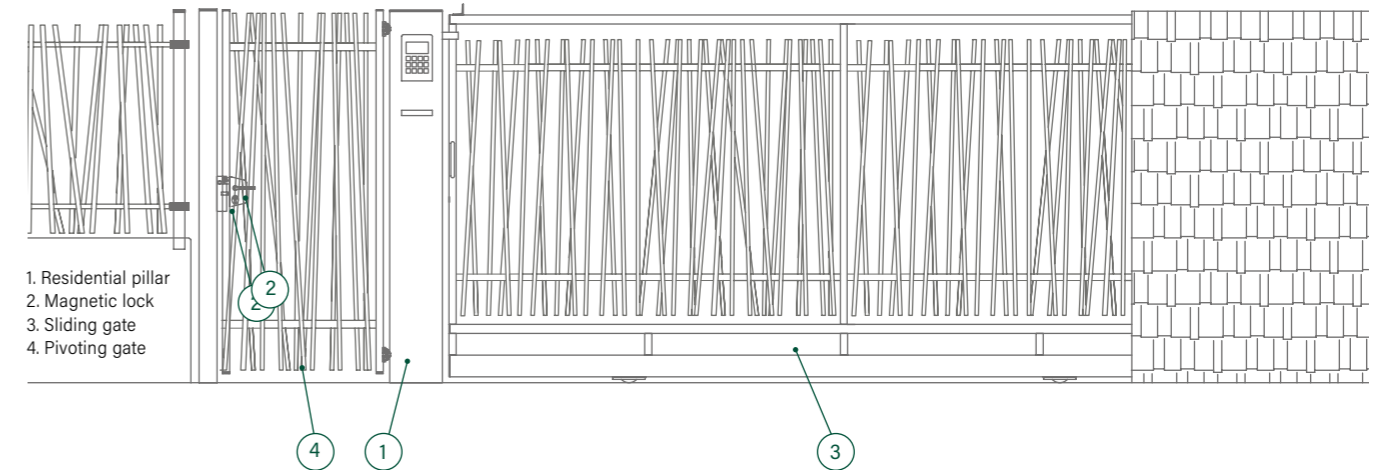

Anticorrosion coating

All the materials of the system are hot-dip galvanised and plastic-coated with the Rivisa® Protecline anticorrosion coating system.

- Minimum thickness: 100 microns
- Option of applying the Rivisa® Protecline Plus plastic coating, which prolongs the useful life of the materials
- Option of applying the Rivisa® Protecline Plus triple plastic coating, which prolongs the useful life of the materials
- Available in several colours from the Rivisa RAL chart. Colours:



protecline

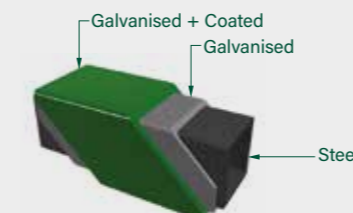

protecline PLUS

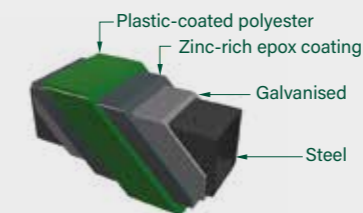

protecline TRIPLE

